

THIS DRAWING IS UNPUBLISHED.  
 VERBODEN TOEGANG TOT DE ZEKERHEIT.  
 (C) COPYRIGHT 2000 BY AMP INCORPORATED. ALL RIGHTS RESERVED.  
 RELEASED FOR PUBLICATION  
 FREI FÜR VERÖFFENTLICHUNG  
 ,2000.  
 MATED WITH:  
 PASSEND ZU:

LOC	DIST	P	LTR	REVISIONS ÄNDERUNGEN DESCRIPTION BESCHREIBUNG	DATE	DWN	APVD
AI	-		B	NEW DRAWING CREATED/NEW VARIANTS ADDED	18AUG00	M. P.	V. H.
			B1	DRAWING REVISED	05JUL01	Abr	M. T.
			B2	TOLERANCE CORRECTED	27FEB02	Abr	M. T.
			B3	NEW PN ADDED/TOLERANCE CORRECTED	16. Jun. 03	ABRAHAM, G.	BRUNNER, M.
			B4	NEW PN ADDED	15. Oct. 03	ABRAHAM, G.	BRUNNER, M.
			B5	NEW DASH NUMBERS ADDED	15. Apr. 05	ABRAHAM, G.	BRUNNER, M.

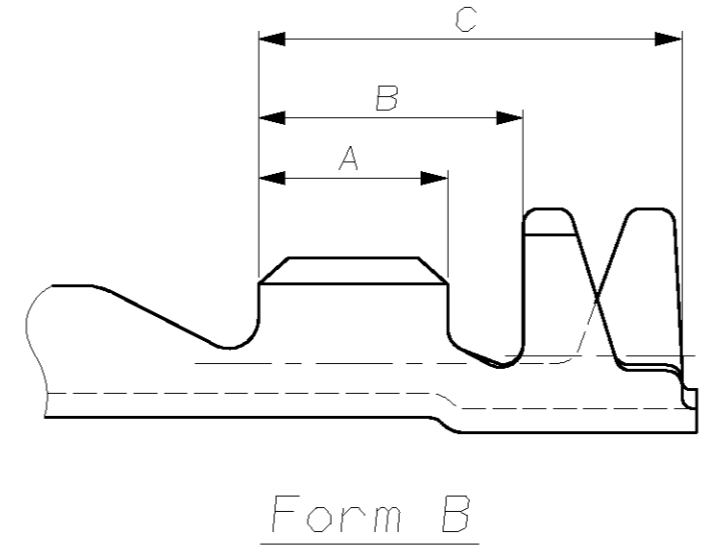

CONTACTS FOR FLR-CABLE  
 Kontakte für FLR-Leitung

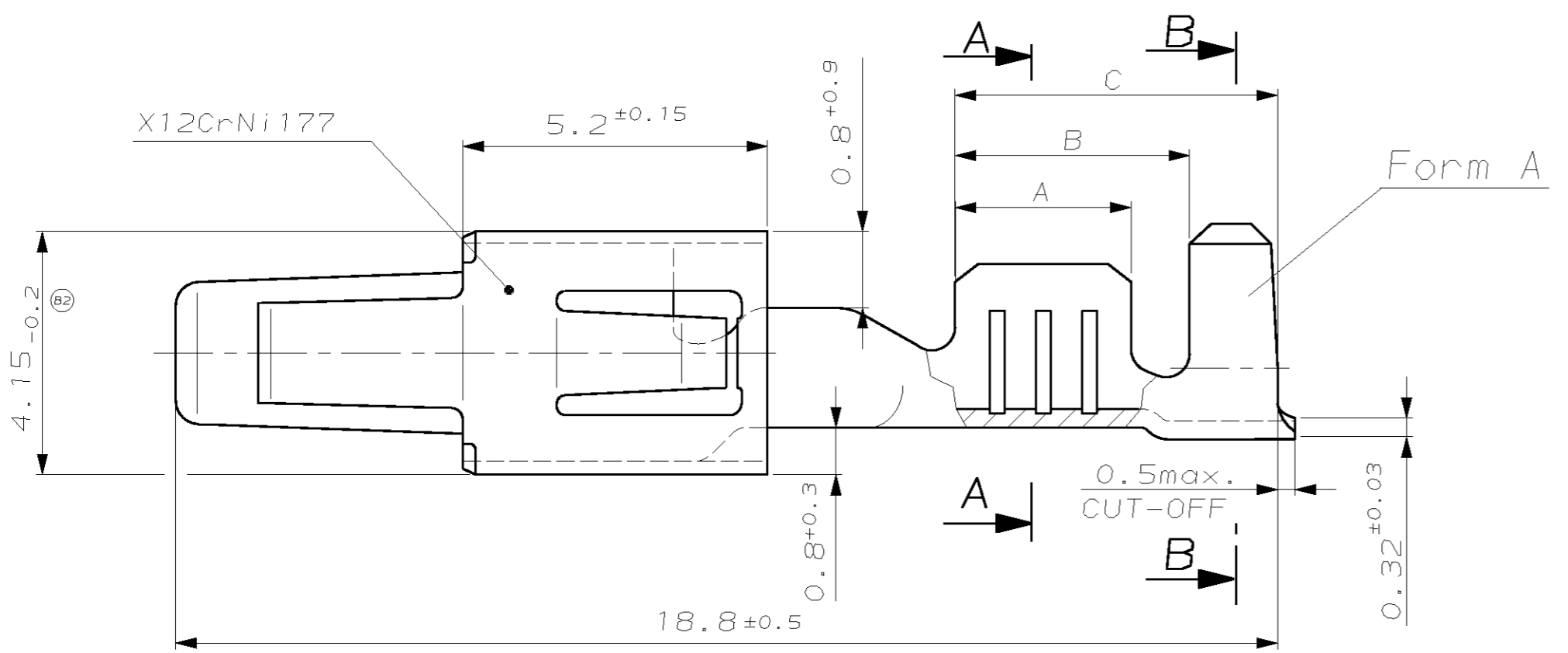
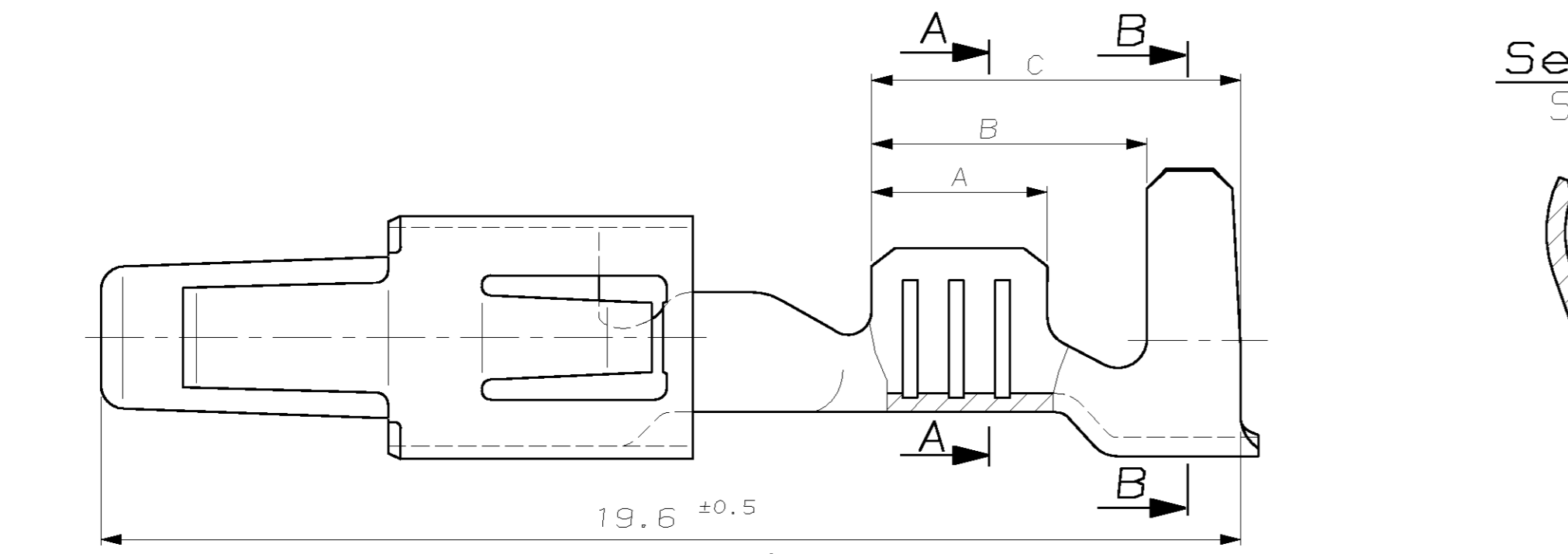
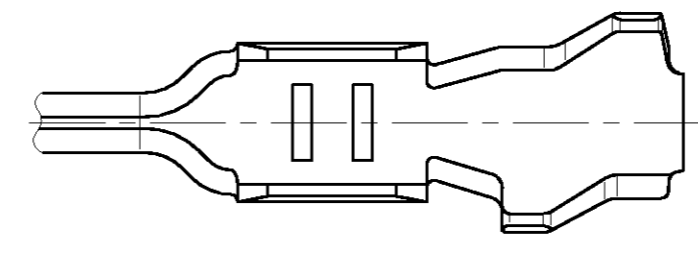
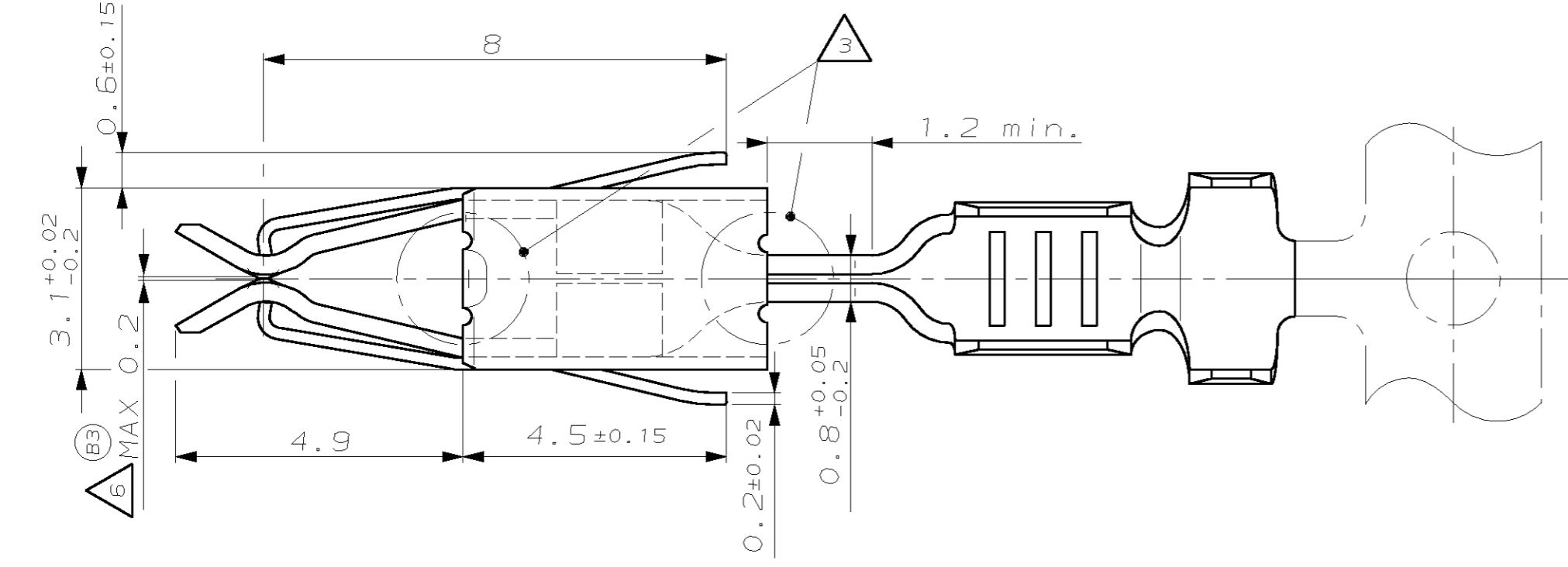

Section B-B  
 Schnitt B-B

CONTACTS FOR SINGLE WIRE SEALING SYSTEM; FLR- AND FLK-CABLE  
 Kontakte für Einzel-Dichtungs-System: FLR- und FLK-Leitung

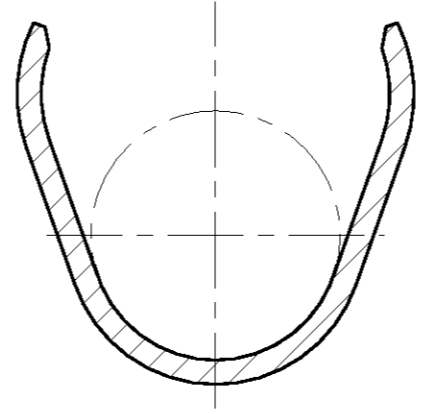

DIMENSIONS SEE FIGURE CONTACTS FOR FLR-CABLE  
 Maße siehe Darstellung der Kontakte für FLR-Leitung

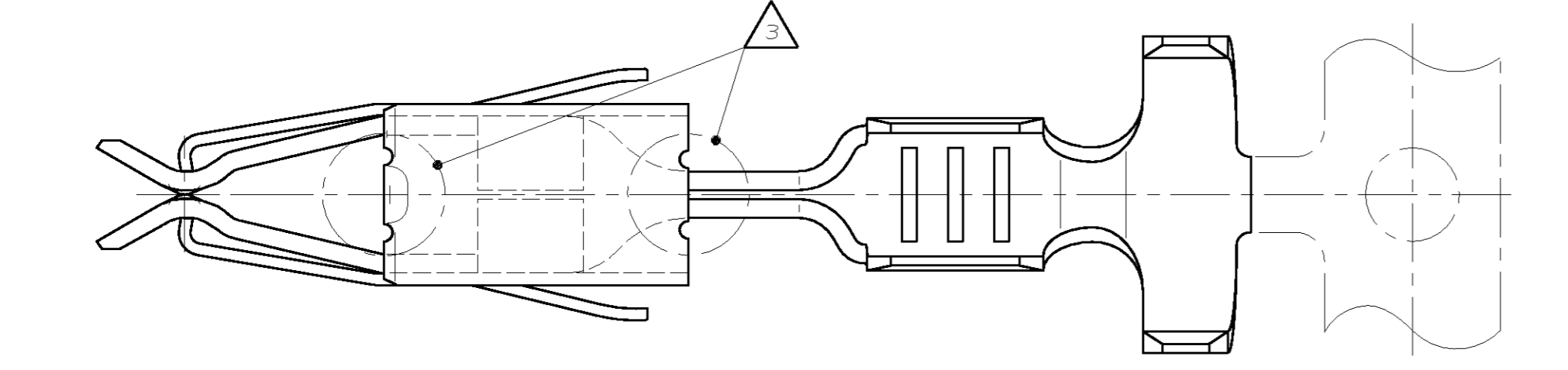

THIS DRAWING IS A CONTROLLED DOCUMENT FOR AMP INCORPORATED. IT IS SUBJECT TO CHANGE AND THE CONTROLLING ENGINEERING ORGANIZATION SHOULD BE CONTACTED FOR THE LATEST REVISION. DIESER ZEICHNUNGSSTATUS WIRD DURCH AMP INCORPORATED KONTROLLIERT. ÄNDERUNGEN, DIE DEN TECHNISCHEN FORTSCHRITT DIENTEN, SIND VORBEHALTEN. DEN JETZIGEN LETZTSTÄNDIGEN ÄNDERUNGSSTAND ERFAHREN SIE AUF ANFRAGE.		DWN M. Pfeilschifter 18-AUG-00 CHK V. Huhn 18-AUG-00 APVD M. Bleicher 02-Jun-03		18-AUG-00 <b>AMP</b> tyco Electronics AMP GmbH D - 64625 Bensheim	
DIMENSIONS: DIMENSIONEN: mm		OTHERWISE SPECIFIED: ALLGEMEINTOLERANZEN: 0 ISO 8015 1 ISO 2768 - mH - E 2 DIN 16901 - 140 3 PLC ± - ANGLES/WINKEL ± - FINISH/OBERFLÄCHE/FARBE -		PRODUCT SPEC. 108-18013 APPLICATION SPEC. 114-18050	
MATERIAL -		WEIGHT GEWICHT -		SIZE A2 CAGE CODE 00779 DRAWING NO. ZEICHNUNGS-NR. C-1355047 RESTRICTED TO NUR FÜR	
CUSTOMER DRAWING /KUNDENZEICHNUNG		MASSSTAB 10:1		BLATT 1 OF 2 REV B5	

LOC	DIST	REVISIONS		
AI	-	ANDERUNGEN	DATE	DWN
PROJEKT NR.:	-	BESCHREIBUNG	-	APVD
		SEE SHEET 1	-	-

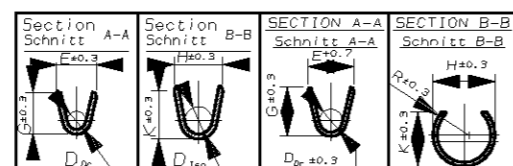

Order No. / Rev.	Order No. / Rev.	Wire Range	Insulation	Material	Surface	Length	Wire crimp	Insul. crimp	Wire crimp	Insul. crimp	Order No.	Order No.	Crimp data		
Bestell-Nr. / Strip-BANDWARE	Bestell-Nr. / Loose piece	Drachtgröße / Bereich (mm²)	Isolations-Ø (mm)	Werkstoff	Oberfläche	Länge	Drachterimp	Isol. crimp	Drachterimp	Isol. crimp	Bestell-Nr.	Bestell-Nr.	Extraction tool		
4-1241872-1	A	4-1241873-1	>1.0-2.5	2.2-3.0	CuNiSi	Δ	A = 3.5 B = 5.2 C = 6.8	E = 3.6 G = 3.8 D <sub>p</sub> = 1.8	H = 5.3 K = 5.0 D <sub>m</sub> = 3.5	E = 2.8 G = 3.9 D <sub>p</sub> = 1.7	H = 4.8 K = 4.5 R = 2.8	Hand tool (nusszange)	169400-0	Insert (matrix)	539614-1
4-1241868-1	A	4-1241869-1	0.5-1.0	1.4-2.7	CuNiSi	Δ	A = 3.0 B = 4.7 C = 6.3	E = 2.5 G = 2.7 D <sub>p</sub> = 1.2	H = 5.1 K = 4.8 D <sub>m</sub> = 3.3	E = 2.2 G = 2.8 D <sub>p</sub> = 1.2	H = 4.4 K = 4.2 R = 2.6	Hand tool (nusszange)	169400-0	Insert (matrix)	539613-1
4-1241864-1	A	4-1241865-1	0.2-0.5	1.2-2.3	CuNiSi	Δ	A = 2.5 B = 4.7 C = 6.3	E = 2.1 G = 2.1 D <sub>p</sub> = 0.8	H = 4.7 K = 4.5 D <sub>m</sub> = 3.2	E = 1.7 G = 2.15 D <sub>p</sub> = 0.8	H = 4.2 K = 4.15 R = 2.4	Hand tool (nusszange)	169400-0	Insert (matrix)	539613-1
4-964273-1	F	964287-5	>1.0-2.5	2.2-3.0	CuNiSi	Δ	A = 3.5 B = 5.2 C = 6.8	E = 3.6 G = 3.8 D <sub>p</sub> = 1.8	H = 5.3 K = 5.0 D <sub>m</sub> = 3.5	E = 2.8 G = 3.9 D <sub>p</sub> = 1.7	H = 4.8 K = 4.5 R = 2.8	Hand tool (nusszange)	169400-0	Insert (matrix)	539613-1
3-964273-1	F	964287-5			CuNiSi	Δ									
2-964273-1	F	964287-4			CuSn 4	Δ									
1-964273-1	F	964287-3			CuFe 2	Δ									
964273-2	F	964287-2			CuSn 4	tin plated vorverzinkt									
4-964286-1	F	964285-5	0.5-1.0	1.4-2.7	CuNiSi	Δ	A = 3.0 B = 4.7 C = 6.3	E = 2.5 G = 2.7 D <sub>p</sub> = 1.2	H = 5.1 K = 4.8 D <sub>m</sub> = 3.3	E = 2.2 G = 2.8 D <sub>p</sub> = 1.2	H = 4.4 K = 4.2 R = 2.6	Hand tool (nusszange)	169400-0	Insert (matrix)	539613-1
4-964282-1	F	964281-5	0.2-0.5	1.2-2.3	CuNiSi	Δ	A = 2.5 B = 4.7 C = 6.3	E = 2.1 G = 2.1 D <sub>p</sub> = 0.8	H = 4.7 K = 4.5 D <sub>m</sub> = 3.2	E = 1.7 G = 2.15 D <sub>p</sub> = 0.8	H = 4.2 K = 4.15 R = 2.4	Hand tool (nusszange)	169400-0	Insert (matrix)	539613-1
4-1241870-1	A	4-1241871-1	>1.0-2.5	2.2-3.0	CuNiSi	Δ	A = 3.3 B = 4.3 C = 5.8	E = 3.6 G = 3.8 D <sub>p</sub> = 1.8	H = 4.7 K = 4.6 D <sub>m</sub> = 2.6	E = 2.8 G = 3.9 D <sub>p</sub> = 1.7	H = 3.8 K = 4.3 R = 2.3	Hand tool (nusszange)	169400-0	Insert (matrix)	539613-1
4-1241866-1	A	4-1241867-1	0.5-1.0	1.4-2.1	CuNiSi	Δ	A = 3.0 B = 4.0 C = 5.5	E = 2.5 G = 2.7 D <sub>p</sub> = 1.2	H = 3.7 K = 3.9 D <sub>m</sub> = 1.8	E = 2.2 G = 2.8 D <sub>p</sub> = 1.2	H = 2.8 K = 3.5 R = 1.6	Hand tool (nusszange)	169400-0	Insert (matrix)	539613-1
4-1241862-1	A	4-1241863-1	0.2-0.5	1.15-1.6	CuNiSi	Δ	A = 2.5 B = 3.5 C = 5.6	E = 2.1 G = 2.1 D <sub>p</sub> = 0.8	H = 2.7 K = 2.8 D <sub>m</sub> = 1.4	E = 1.7 G = 2.15 D <sub>p</sub> = 0.8	H = 2.5 K = 2.4 R = 1.4	Hand tool (nusszange)	169400-0	Insert (matrix)	539613-1
4-1241978-2	A	1241977-2	>2.5-4.0	2.7-3.7	CuSn 4	tin plated vorverzinkt	A = 3.6 B = 5.0 C = 6.5	E = 4.5 G = 4.7 D <sub>p</sub> = 2.3	H = 5.8 K = 6.0 D <sub>m</sub> = 3.3	E = 3.4 G = 4.8 D <sub>p</sub> = 2.3	H = 4.4 K = 5.1 R = 2.6	Hand tool (nusszange) / Leitung	-	-	-
4-965999-1	F	964346-5	>1.0-2.5	2.2-3.0	CuNiSi	Δ	A = 3.3 B = 4.3 C = 5.8	E = 3.6 G = 3.8 D <sub>p</sub> = 1.8	H = 4.7 K = 4.9 D <sub>m</sub> = 2.6	E = 2.8 G = 3.9 D <sub>p</sub> = 1.7	H = 3.8 K = 4.5 R = 2.3	Hand tool (nusszange)	169400-0	Insert (matrix)	539613-1
2-965999-1	F	964346-4			CuSn 4	Δ									
1-965999-1	F	964346-3			CuFe 2	Δ									
965999-6	A	964346-6			CuSn 4	Δ									
965999-2	F	964346-2			CuSn 4	tin plated vorverzinkt									
4-964284-1	F	964283-5	0.5-1.0	1.4-2.1	CuNiSi	Δ	A = 3.0 B = 4.0 C = 5.5	E = 2.5 G = 2.7 D <sub>p</sub> = 1.2	H = 3.7 K = 3.9 D <sub>m</sub> = 1.8	E = 2.2 G = 2.8 D <sub>p</sub> = 1.2	H = 2.8 K = 3.5 R = 1.6	Hand tool (nusszange)	169400-0	Insert (matrix)	539613-1
4-964280-1	F	964279-5	0.2-0.5	1.15-1.6	CuNiSi	Δ	A = 2.5 B = 3.5 C = 5.6	E = 2.1 G = 2.1 D <sub>p</sub> = 0.8	H = 2.7 K = 2.8 D <sub>m</sub> = 1.4	E = 1.7 G = 2.15 D <sub>p</sub> = 0.8	H = 2.5 K = 2.4 R = 1.4	Hand tool (nusszange)	169400-0	Insert (matrix)	539613-1
2-964280-1	F	964279-4			CuSn 4	Δ									
1-964280-1	F	964279-3			CuFe 2	Δ									
964280-2	F	964279-2			CuSn 4	tin plated vorverzinkt									
964280-1	F	964279-1			CuFe 2	tin plated vorverzinkt									

Hand tool (nusszange) / Insert (matrix)

968 107-1

see Application specification  
siehe Verarbeitungsspezifikation  
114-18050

Single Wire Seal Einzel-Dichtung		
963292-1	2.7-3.0	yellow gelb
963293-1	2.0-2.7	redbrown rotbraun
963294-1	1.2-2.1	blue blau
ORDER NO. BESTELL-NR.	Insulation Ø Isolations Ø	Colour Farbe

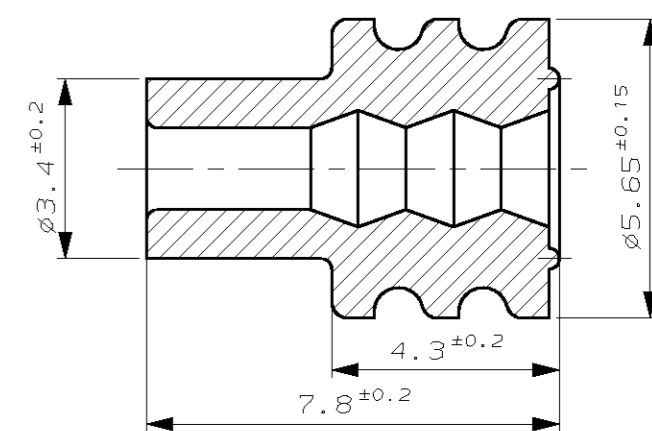

NOTES  
Bemerkungen

- 1 BODY ELECTRO TIN PLATED OVER NICKEL  
Kontaktkörper gal. verzinkt über Nickel 0.2 µm min.  
CONTACT AREA SELECTIV GOLD OVER NICKEL  
Kontaktzone selectiv vergoldet über Ni 0.8 µm min.  
WIRE CRIMP AREA ELECTRO TIN PLATED OVER NICKEL  
Drachtrimpbereich galv. verzinkt über Nickel 1 µm min.
- 2 ACCORDING INSULATION Ø IS TO CHOOSE THE SINGLE WIRE SEAL  
Entsprechend dem Isolationsdurchmesser ist die Einzel-Dichtung auszuwählen
- 3 CUT OFF OPTIONAL  
Optionaler Federabschnitt
- 4 INSULATION BARREL DESIGN OPTIONAL  
Ausführung Isolationshülse wahlweise
- 5 VARIANTS WITH GAP-SIZE 0.3mm  
Varianten mit Gap-Size 0.3mm
- 6 FOR EVALUATION OF THE GAP-SIZE, THE MATING-FORCE HAS PRIORITY.  
Zur Beurteilung des Öffnungsmaßes ist die Steckkraft ausschlaggebend.
- 7 CONTACT BODY PRE SILVER PLATED MIN. 0.8µm  
CONTACT ZONE SELECTIVE PRE SILVER PLATED MIN. 3µm  
Kontaktkörper vorversilbert min. 0.8µm  
Kontaktzone selektiv vorversilbert min. 3µm

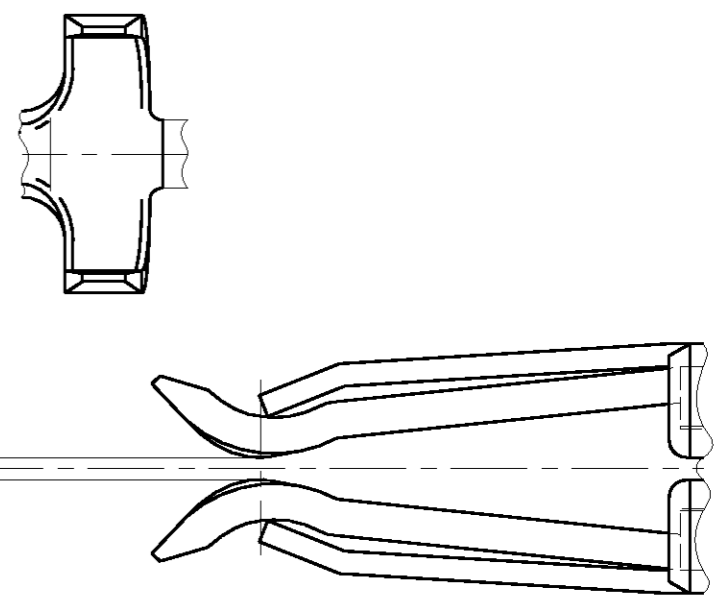

THIS DRAWING IS A CONTROLLED DOCUMENT FOR AMP INCORPORATED. IT IS SUBJECT TO CHANGE AND THE CONTROLLING ENGINEERING ORGANIZATION SHOULD BE CONTACTED FOR THE LATEST REVISION. DIESER ZEICHNUNGS-DOKUMENT WIRD DURCH AMP INCORPORATED KONTROLLIERT. ÄNDERUNGEN, DIE DEN TECHNISCHEN FORTSCHRITT DIENTEN, SIND VORBEHALTEN. DEN JEWELIGS LETZTLIEGENEN ÄNDERUNGSSTAND BEFOLGEN SIE AUF FORDERUNG.		DWN M. Pfeilschifter 21-AUG-00	21-AUG-00	AMP tyco Electronics AMP GmbH D - 64625 Bensheim	
DIMENSIONS: mm		CHK V. Huhn 21-AUG-00	APVD M. Bleicher 02-JUN-03	NAME Junior Power Timer Typ A Product Group Drawing JPT Typ A Kundensammelzeichnung	
OTHERWISE SPECIFIED: TOLERANCES UNLESS OTHERWISE SPECIFIED: ±0.2mm n. ISO 8015 P. ISO 2768 - mH - E P. DIN 16901 - 140		APPLICATION SPEC VERARBEITUNGSSPEZ. 114-18050		SIZE A2	CAGE CODE 00779
MATERIAL		WEIGHT GEWICHT		DRAWING NO. ZEICHNUNGS-NR. C-1355047	RESTRICTED TO NUR FÜR B5
CUSTOMER DRAWING		/KUNDENZEICHNUNG		MASSSTAB 10:1	BLATT 2 VON 2